

# SECTION 2 - PERIODIC MAINTENANCE/TUNE-UP

---

---

## TABLE OF CONTENTS

---

Periodic Maintenance Chart.....	2-2
Lubrication Points.....	2-3
Battery.....	2-3
Fuses.....	2-4
Air Cleaner.....	2-4
Valve/Tappet Clearance.....	2-6
Tappet Shim Selection Table (Exhaust).....	2-9
Tappet Shim Selection Table (Intake).....	2-10
Testing Engine Compression.....	2-11
Spark Plug.....	2-11
Muffler/Spark Arrester.....	2-12
Gas/Vent Hoses.....	2-12
Adjusting Throttle Cable.....	2-12
Adjusting Engine RPM (Idle).....	2-13
Engine/Transmission Oil - Filter.....	2-13
Adjusting Clutch Lever Cable.....	2-14
Tires.....	2-15
Steering Components.....	2-15
Suspension/Shock Absorbers/Bushings.....	2-15
Nuts/Bolts/Cap Screws.....	2-15
Headlight/Taillight-Brakelight.....	2-15
Switches.....	2-17
Indicator Lights.....	2-17
Frame/Welds.....	2-17
Electrical Connections.....	2-17
Hydraulic/Parking Brake Systems.....	2-17
Burnishing Brake Pads.....	2-22
Coolant.....	2-22
Drive Chain.....	2-22

# Periodic Maintenance Chart

A = Adjust  
C = Clean  
D = Drain

I = Inspect  
L = Lubricate  
R = Replace

Item	Initial Service After Break-In (First Mo)	Every Day	Every Month	Every 3 Months	Every 6 Months	Every Year	As Needed
Battery			Charge				C
Fuse				I			R
Air Filter/Drain Tube	I	I	C*				R
Valve/Tappet Clearance	I				I		A
Engine Compression						I	
Spark Plug	I				I		R (18 Mo)
Muffler/Spark Arrester					C		R
Gas/Vent Hoses	I	I					R (2 Yrs)
Gas Tank Valve						I	C
Throttle Cable	I	I			C-L		A-R
Carb Float Chamber				D*			
Engine RPM (Idle)	I				I		A
Engine-Transmission Oil Level		I					A
Engine-Transmission Oil/Filter	R			R*			R
Oil Strainer	I				I		C
Drive Chain	I	I	A				R
Clutch	I				I		A
Tires/Air Pressure	I	I					R
Steering Components	I	I					R
Coolant Hoses	I				I		R (4 yrs)
Suspension (Ball joint and tie rod boots, tie rods, and shock mounts)	I			I*			R
Nuts/Cap Screws/Screws	I	I					A
Oil Lines	I	I					
Headlight/Taillight-Brakelight	I	I					R
Switches	I	I					R
Reverse Selector Cable	I				I		A-L
Choke Cable	I			I	C-L		R
Handlebar Grips		I					R
Handlebars	I	I					R
Indicator Lights	I	I					R
Frame/Welds	I		I		I		
Electrical Connections					I		C
Complete Brake Systems (Hydraulic & Parking)	I	I		C			L-R
Brake Pads	I			I*			R
Brake Fluid	I			I			R (2 Yrs)
Brake Hoses	I			I			R (4 Yrs)
Brake Cable (Parking)		I-A					
Coolant/Cooling System	I		I				R (2 Yrs)

\* Service/Inspect more frequently when operating in adverse conditions.

---

---

## Lubrication Points

---

It is advisable to lubricate certain components periodically to ensure free movement. Apply light oil to the components using the following list as reference.

- A. Throttle Lever Pivot/Cable Ends
- B. Brake Lever Pivot
- C. Parking Brake Cable Ends
- D. Choke Cable Upper End
- E. Reverse Selector Cable End
- F. Idle RPM Screw (Carburetor)
- G. Rear Brake Pedal Pivot

---

---

## Battery

---

The battery is located under the seat.

The battery in this ATV is a “sealed” type and does not require any maintenance unless discharged. Distilled water and/or electrolyte cannot be added to the battery.

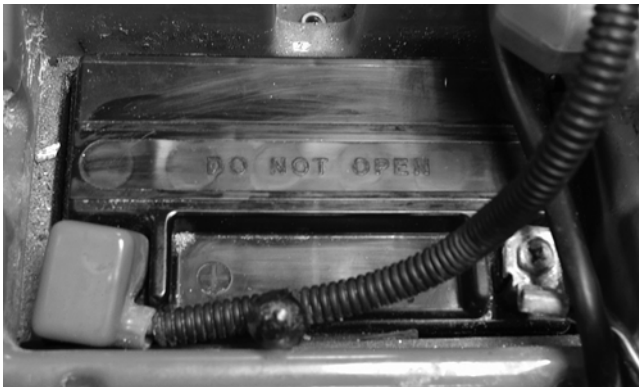

SP034

### **WARNING**

Anytime service is performed on a battery, the following must be observed: Keep sparks, open flame, cigarettes, or any other flame away. Always wear safety glasses. Protect skin and clothing when handling batteries. When servicing battery in enclosed space, keep the area well-ventilated.

This maintenance-free battery requires periodic charging to prevent sulfiding. If the ATV will be idle for extended periods of time, either run the engine or trickle charge from time to time. If the battery completely discharges, permanent damage will occur requiring replacement.

[Back to Table of Contents](#)

If the battery is discharged, remove the battery from the ATV and charge the battery at the standard charging rate of 0.9 amps for 5-10 hours.

To remove and charge the battery, use the following procedure.

1. Remove the seat; then remove the battery hold-down bracket.
2. Remove the negative battery cable; then remove the positive cable and the battery vent tube. Remove the battery from the ATV. Care should be taken not to damage the vent tube.

### **WARNING**

Avoid spillage and contact with skin, eyes, and clothing.

### **CAUTION**

Do not charge the battery while it is in the ATV with the battery terminals connected.

3. Trickle charge the battery at 0.9 amps for 5-10 hours.

### **CAUTION**

Never exceed the standard charging rate.

### **CAUTION**

Before installing the battery, make sure the ignition switch is in the OFF position.

4. Place the battery into position in the ATV and secure with the hold-down bracket.
5. Connect cables to the proper terminals: positive cable to the positive terminal (+) and negative cable to the negative terminal (-). Connect the negative cable last.

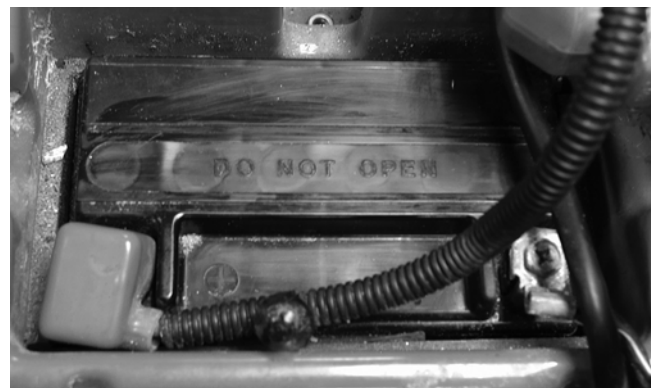

SP034

### **CAUTION**

Connecting cables in reverse (positive to negative and negative to positive) can cause serious damage to the electrical system.

[Back to Section TOC](#)

6. Install the seat making sure it locks securely.

---

---

## FUSES

---

There is one 20 amp fuse and one spare 20 amp fuse located adjacent to the battery on the starter relay.

If there is any type of electrical system failure, always check the fuse first.

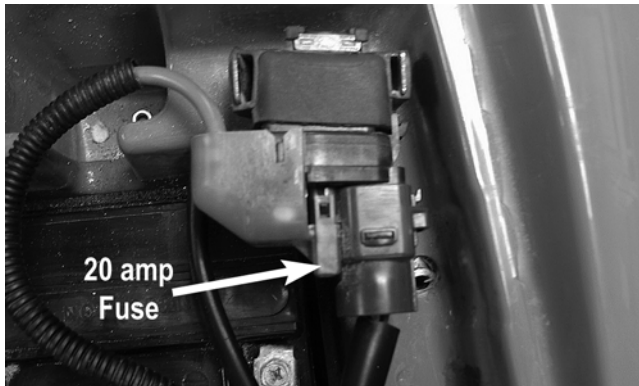

SP032A

**⚠ CAUTION**

Always replace a blown fuse with a fuse of the same type and rating.

---

---

## Air Cleaner

---

The air filter inside the air cleaner must be kept clean to provide good engine power and gas mileage. If the ATV is used under normal conditions, service the filter at the intervals specified. If operated in dusty, wet, or muddy conditions, inspect and service the filter more frequently.

### CLEANING AND INSPECTING FILTER

**⚠ CAUTION**

Failure to inspect the air filter frequently if the ATV is used in dusty, wet, or muddy conditions can damage the ATV engine.

1. Remove the seat.
2. Unseat the two retaining clips securing the air cleaner housing cover; then remove the cover.

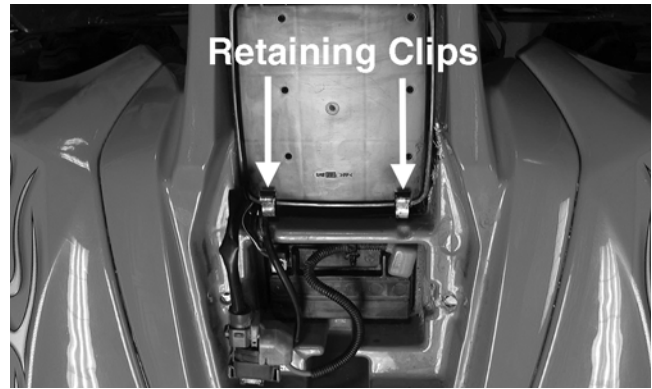

SP014A

3. Remove the screw securing the air filter stopper and set aside; then remove the filter assembly.

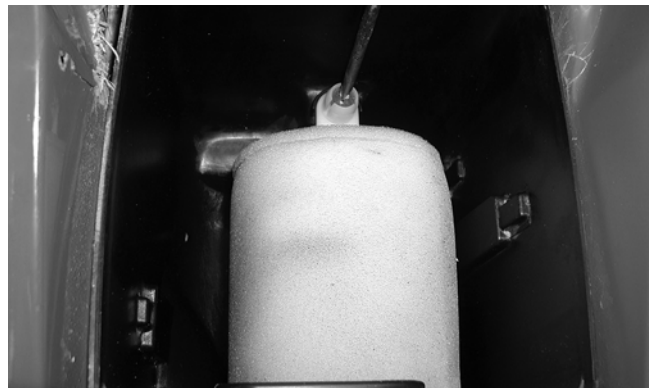

SP012

4. Remove the foam wrap from the filter frame.

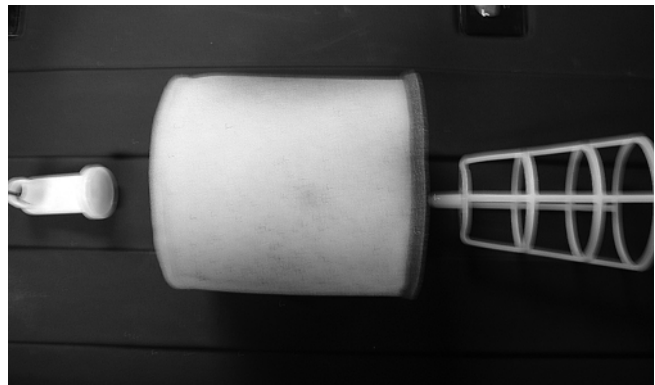

SP013

5. Fill a wash pan larger than the filter with a non-flammable cleaning solvent; then dip the filter in the solvent and wash it.

■ **NOTE:** Foam Filter Cleaner (p/n 0436-194) and Foam Filter Oil (p/n 0436-195) are available from Arctic Cat.

6. Dry the filter.



- Put the filter in a plastic bag; then pour in air filter oil and work the filter.

**CAUTION**

A torn air filter can cause damage to the ATV engine. Dirt and dust may get inside the engine if the element is torn. Carefully examine the element for tears before and after cleaning it. Replace the element with a new one if it is torn.

- Clean any dirt or debris from inside the air cleaner. Be sure no dirt enters the carburetor.
- Place the filter in the air filter housing making sure it is properly in position and properly seated and secure with the stopper and screw.
- Install the air filter housing cover and secure with the retaining clips; then install the seat making sure the seat is properly secured.

**CHECKING/DRAINING DRAIN TUBE**

- Periodically check the drain tube for gasoline or oil accumulation. If noticed, remove the drain tube cap from beneath the front housing, drain the gasoline or oil into a suitable container, and install and secure the tube cap.
- Inspect one-way drain tube beneath the main housing for debris and for proper sealing.

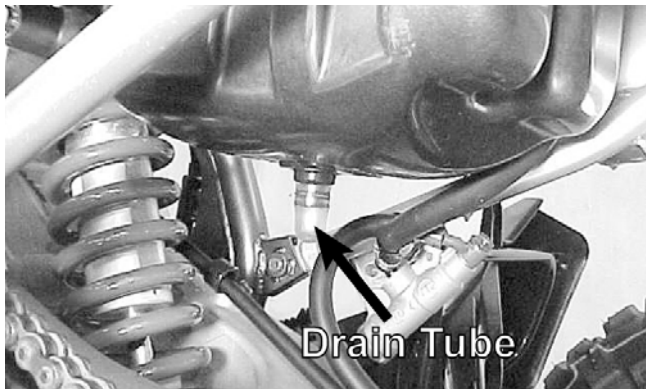

SP119

**REMOVING**

- Remove the seat.
- Unseat the two retaining clips securing the air cleaner housing; then remove the cover.

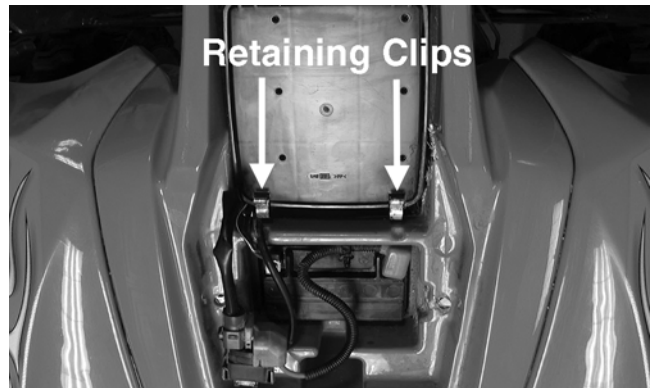

SP014A

- Remove the screw securing the air filter stopper and set aside; then remove the air filter.

**2**

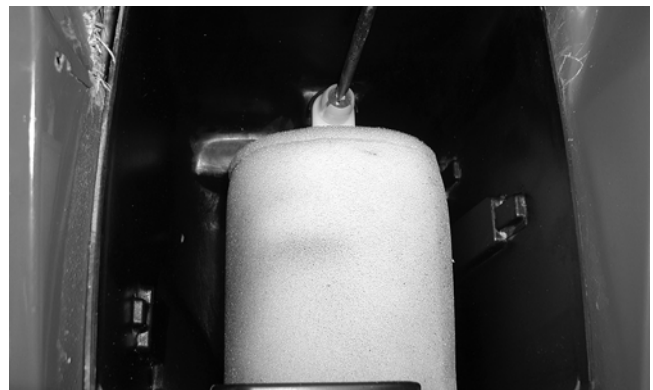

SP012

- Loosen the clamp securing the air cleaner to the inlet duct; then loosen the clamp securing the air cleaner to the outlet tube.
- Remove the cap screws securing the air cleaner to the frame.
- Remove the air cleaner from the frame.

**INSTALLING**

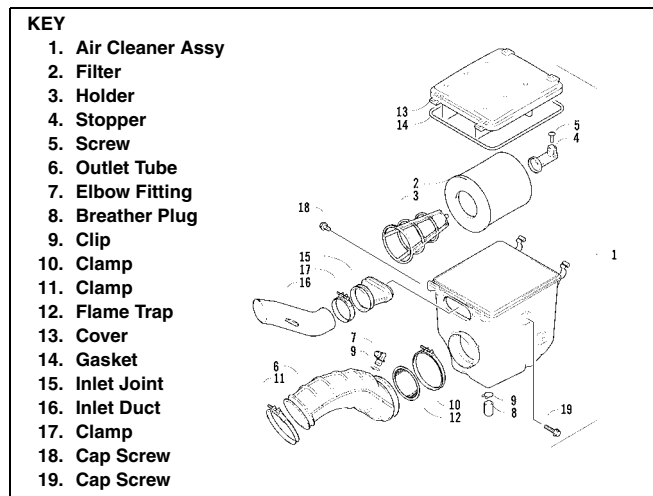

0739-212

- Place the air cleaner into the frame.
- Install the cap screws securing the air cleaner to the frame.

3. Install the outlet tube onto the air cleaner; then tighten the clamp securely.
4. Install the inlet duct onto the air cleaner; then tighten the clamp securely.
5. Install the filter with foam wrap into the air cleaner; then tighten the filter stopper screw securely.

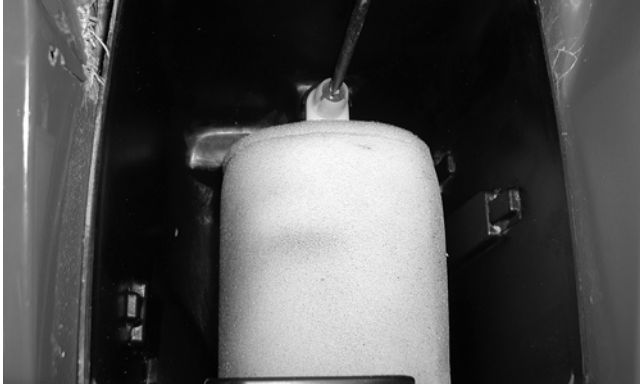

SP012

6. Place the air cleaner cover into position and secure with the retaining clips.

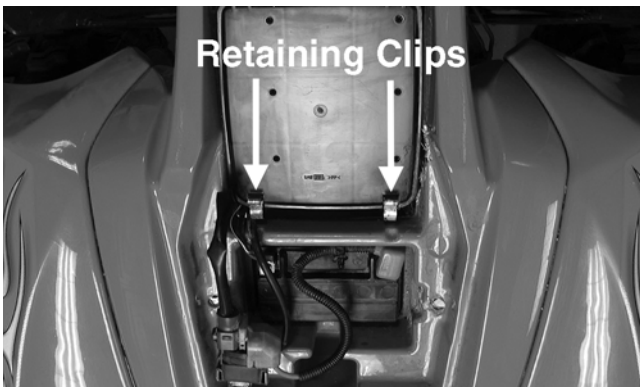

SP014A

7. Install the seat making sure the seat is properly secured.

---



---

## Valve/Tappet Clearance

---

### CHECKING

To check and adjust valve/tappet clearance, use the following procedure.

1. Remove the seat, gas tank cover, and body.
2. Turn the fuel valve to the “ON” position; then remove the gas tank.
3. Disconnect the engine oil hose (3) and the engine oil breather hose (4); then remove the spark plug.

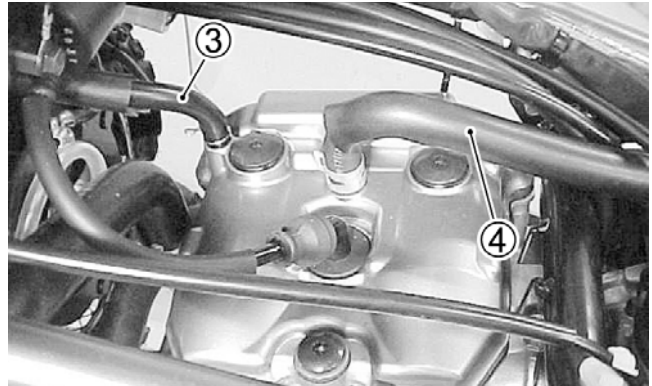

SP120

4. Remove the three large Allen-head cap screws securing the valve cover; then remove the valve cover accounting for the two camshaft end plugs and the valve cover gasket.

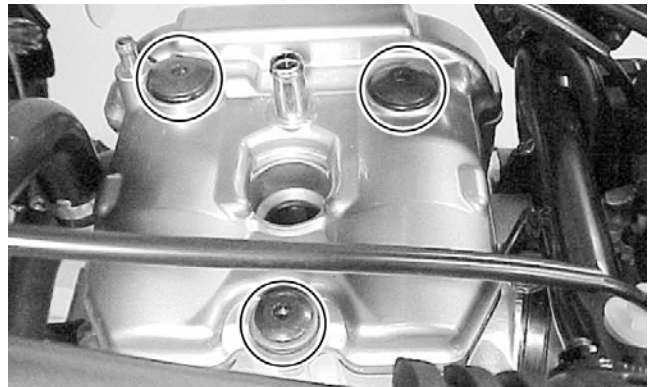

SP121

■ **NOTE:** The valve/tappet clearance specification is different for intake and exhaust valves. The clearance should only be checked when the engine is cold (room temperature).

■ **NOTE:** Valve/tappet clearance adjustment must be checked and adjusted in accordance with the periodic maintenance chart or anytime valve mechanism components are removed and reinstalled.

5. Remove the valve timing inspection plug (1) and the generator cover cap (2); then rotate the crankshaft with a socket wrench to top-dead-center (TDC) on the compression stroke. The “T” line on the alternator rotor is aligned with the triangle mark on the alternator cover.

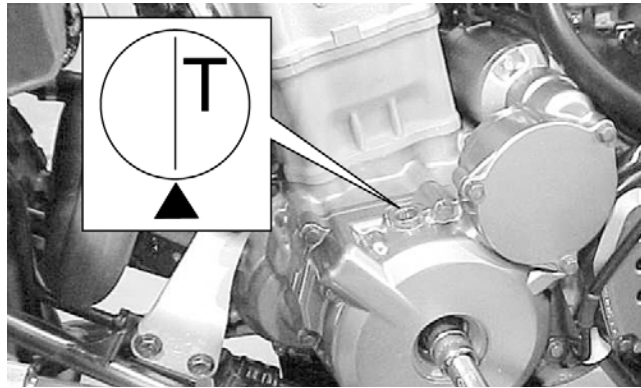
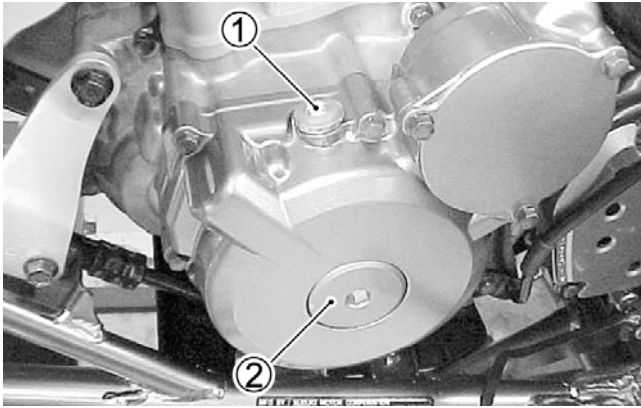

■ **NOTE:** The camshaft lobes must be in position (A) in order to check valve/tappet clearance.

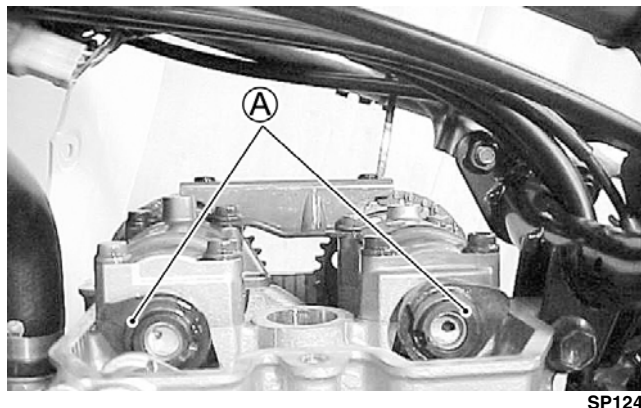

6. Insert a feeler gauge between the tappet and the camshaft. The clearance must be within specifications.



If the clearance is out of specifications, adjust the clearance using the following procedure.

### ADJUSTING

The clearance is adjusted by replacing the existing tappet shim with a thicker or thinner shim.

**2**

1. Remove the camshaft corresponding to the out-of-tolerance tappet. See Section 3.
2. Using a magnet, remove the tappet and shim; then check the numbers printed on the tappet shim.

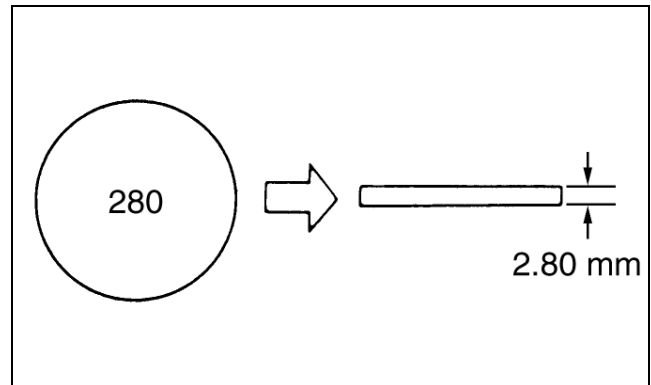

■ **NOTE:** These numbers indicate the thickness of the tappet shim as illustrated.

3. Select a replacement tappet shim that will provide the proper clearance.

■ **NOTE:** Tappet shims are available in 25 sizes from 2.30-3.50 mm (0.09-0.14 in.) in 0.05 mm (0.002 in.) increments.

4. Install the selected shim at the valve stem with the numbers facing the tappet. Be sure to measure the shim with a micrometer to ensure it is the proper size. Refer to the tappet shim selection table for details.

■ **NOTE:** Apply molybdenum oil solution to the top and bottom of the tappet shim. Make sure that the numbered side is directed toward the tappet.

5. Install the camshaft (see Section 3).



6. Rotate the crankshaft through two full revolutions to ensure that all excess oil is squeezed from the valve/tappet clearance to make sure it is within specifications.
7. Apply Three Bond Sealant (p/n 0636-070) to the camshaft end caps of the valve cover gasket; then install the valve cover.
8. Tighten the valve cover cap screws to specifications.
9. Install the spark plug and tighten to specifications; then install the timing inspection plug.



**TAPPET SHIM SELECTION TABLE (EXHAUST)  
TAPPET SHIM SET (p/n 3402-931)**

MEASURED TAPPET CLEARANCE (mm)	SPECIFIED CLEARANCE/NO ADJUSTMENT REQUIRED																								
	230	235	240	245	250	255	260	265	270	275	280	285	290	295	300	305	310	315	320	325	330	335	340	345	350
0.00-0.04	2.30	2.35	2.40	2.45	2.50	2.55	2.60	2.65	2.70	2.75	2.80	2.85	2.90	2.95	3.00	3.05	3.10	3.15	3.20	3.25	3.30	3.35	3.40	3.45	3.50
0.05-0.09	2.30	2.35	2.40	2.45	2.50	2.55	2.60	2.65	2.70	2.75	2.80	2.85	2.90	2.95	3.00	3.05	3.10	3.15	3.20	3.25	3.30	3.35	3.40	3.45	3.50
0.10-0.14	2.30	2.35	2.40	2.45	2.50	2.55	2.60	2.65	2.70	2.75	2.80	2.85	2.90	2.95	3.00	3.05	3.10	3.15	3.20	3.25	3.30	3.35	3.40	3.45	3.50
0.15-0.19	2.30	2.35	2.40	2.45	2.50	2.55	2.60	2.65	2.70	2.75	2.80	2.85	2.90	2.95	3.00	3.05	3.10	3.15	3.20	3.25	3.30	3.35	3.40	3.45	3.50
0.20-0.30	2.40	2.45	2.50	2.55	2.60	2.65	2.70	2.75	2.80	2.85	2.90	2.95	3.00	3.05	3.10	3.15	3.20	3.25	3.30	3.35	3.40	3.45	3.50	3.50	3.50
0.31-0.35	2.45	2.50	2.55	2.60	2.65	2.70	2.75	2.80	2.85	2.90	2.95	3.00	3.05	3.10	3.15	3.20	3.25	3.30	3.35	3.40	3.45	3.50	3.50	3.50	3.50
0.36-0.40	2.50	2.55	2.60	2.65	2.70	2.75	2.80	2.85	2.90	2.95	3.00	3.05	3.10	3.15	3.20	3.25	3.30	3.35	3.40	3.45	3.50	3.50	3.50	3.50	3.50
0.41-0.45	2.55	2.60	2.65	2.70	2.75	2.80	2.85	2.90	2.95	3.00	3.05	3.10	3.15	3.20	3.25	3.30	3.35	3.40	3.45	3.50	3.50	3.50	3.50	3.50	3.50
0.46-0.50	2.60	2.65	2.70	2.75	2.80	2.85	2.90	2.95	3.00	3.05	3.10	3.15	3.20	3.25	3.30	3.35	3.40	3.45	3.50	3.50	3.50	3.50	3.50	3.50	3.50
0.51-0.55	2.65	2.70	2.75	2.80	2.85	2.90	2.95	3.00	3.05	3.10	3.15	3.20	3.25	3.30	3.35	3.40	3.45	3.50	3.50	3.50	3.50	3.50	3.50	3.50	3.50
0.56-0.60	2.70	2.75	2.80	2.85	2.90	2.95	3.00	3.05	3.10	3.15	3.20	3.25	3.30	3.35	3.40	3.45	3.50	3.50	3.50	3.50	3.50	3.50	3.50	3.50	3.50
0.61-0.65	2.75	2.80	2.85	2.90	2.95	3.00	3.05	3.10	3.15	3.20	3.25	3.30	3.35	3.40	3.45	3.50	3.50	3.50	3.50	3.50	3.50	3.50	3.50	3.50	3.50
0.66-0.70	2.80	2.85	2.90	2.95	3.00	3.05	3.10	3.15	3.20	3.25	3.30	3.35	3.40	3.45	3.50	3.50	3.50	3.50	3.50	3.50	3.50	3.50	3.50	3.50	3.50
0.71-0.75	2.85	2.90	2.95	3.00	3.05	3.10	3.15	3.20	3.25	3.30	3.35	3.40	3.45	3.50	3.50	3.50	3.50	3.50	3.50	3.50	3.50	3.50	3.50	3.50	3.50
0.76-0.80	2.90	2.95	3.00	3.05	3.10	3.15	3.20	3.25	3.30	3.35	3.40	3.45	3.50	3.50	3.50	3.50	3.50	3.50	3.50	3.50	3.50	3.50	3.50	3.50	3.50
0.81-0.85	2.95	3.00	3.05	3.10	3.15	3.20	3.25	3.30	3.35	3.40	3.45	3.50	3.50	3.50	3.50	3.50	3.50	3.50	3.50	3.50	3.50	3.50	3.50	3.50	3.50
0.86-0.90	3.00	3.05	3.10	3.15	3.20	3.25	3.30	3.35	3.40	3.45	3.50	3.50	3.50	3.50	3.50	3.50	3.50	3.50	3.50	3.50	3.50	3.50	3.50	3.50	3.50
0.91-0.95	3.05	3.10	3.15	3.20	3.25	3.30	3.35	3.40	3.45	3.50	3.50	3.50	3.50	3.50	3.50	3.50	3.50	3.50	3.50	3.50	3.50	3.50	3.50	3.50	3.50
0.96-1.00	3.10	3.15	3.20	3.25	3.30	3.35	3.40	3.45	3.50	3.50	3.50	3.50	3.50	3.50	3.50	3.50	3.50	3.50	3.50	3.50	3.50	3.50	3.50	3.50	3.50
1.01-1.05	3.15	3.20	3.25	3.30	3.35	3.40	3.45	3.50	3.50	3.50	3.50	3.50	3.50	3.50	3.50	3.50	3.50	3.50	3.50	3.50	3.50	3.50	3.50	3.50	3.50
1.06-1.10	3.20	3.25	3.30	3.35	3.40	3.45	3.50	3.50	3.50	3.50	3.50	3.50	3.50	3.50	3.50	3.50	3.50	3.50	3.50	3.50	3.50	3.50	3.50	3.50	3.50
1.11-1.15	3.25	3.30	3.35	3.40	3.45	3.50	3.50	3.50	3.50	3.50	3.50	3.50	3.50	3.50	3.50	3.50	3.50	3.50	3.50	3.50	3.50	3.50	3.50	3.50	3.50
1.16-1.20	3.30	3.35	3.40	3.45	3.50	3.50	3.50	3.50	3.50	3.50	3.50	3.50	3.50	3.50	3.50	3.50	3.50	3.50	3.50	3.50	3.50	3.50	3.50	3.50	3.50
1.21-1.25	3.35	3.40	3.45	3.50	3.50	3.50	3.50	3.50	3.50	3.50	3.50	3.50	3.50	3.50	3.50	3.50	3.50	3.50	3.50	3.50	3.50	3.50	3.50	3.50	3.50
1.26-1.30	3.40	3.45	3.50	3.50	3.50	3.50	3.50	3.50	3.50	3.50	3.50	3.50	3.50	3.50	3.50	3.50	3.50	3.50	3.50	3.50	3.50	3.50	3.50	3.50	3.50
1.31-1.35	3.45	3.50	3.50	3.50	3.50	3.50	3.50	3.50	3.50	3.50	3.50	3.50	3.50	3.50	3.50	3.50	3.50	3.50	3.50	3.50	3.50	3.50	3.50	3.50	3.50
1.36-1.40	3.50	3.50	3.50	3.50	3.50	3.50	3.50	3.50	3.50	3.50	3.50	3.50	3.50	3.50	3.50	3.50	3.50	3.50	3.50	3.50	3.50	3.50	3.50	3.50	3.50
1.41-1.45	3.50	3.50	3.50	3.50	3.50	3.50	3.50	3.50	3.50	3.50	3.50	3.50	3.50	3.50	3.50	3.50	3.50	3.50	3.50	3.50	3.50	3.50	3.50	3.50	3.50
1.46-1.50	3.50	3.50	3.50	3.50	3.50	3.50	3.50	3.50	3.50	3.50	3.50	3.50	3.50	3.50	3.50	3.50	3.50	3.50	3.50	3.50	3.50	3.50	3.50	3.50	3.50

**How to use this chart:**

- I. Measure tappet clearance when the engine is cold.
- II. Measure present shim size.
- III. Match clearance in vertical column with present shim size in horizontal column.

**Example:**

Tappet clearance is 0.38 mm  
 Present shim size 2.90 mm  
 Shim size to be used 3.05 mm

Back to Table of Contents

Back to Section TOC

### TAPPET SHIM SELECTION TABLE (INTAKE) TAPPET SHIM SET (p/n 3402-931)

MEASURED TAPPET CLEARANCE (mm)	SUFFIX NO.	SPECIFIED CLEARANCE/NO ADJUSTMENT REQUIRED																								
		230	235	240	245	250	255	260	265	270	275	280	285	290	295	300	305	310	315	320	325	330	335	340	345	350
0.00-0.04	2.30	2.30	2.35	2.40	2.45	2.50	2.55	2.60	2.65	2.70	2.75	2.80	2.85	2.90	2.95	3.00	3.05	3.10	3.15	3.20	3.25	3.30	3.35	3.40	3.45	3.50
0.05-0.09	2.30	2.30	2.35	2.40	2.45	2.50	2.55	2.60	2.65	2.70	2.75	2.80	2.85	2.90	2.95	3.00	3.05	3.10	3.15	3.20	3.25	3.30	3.35	3.40	3.45	3.50
0.10-0.20	2.40	2.45	2.50	2.55	2.60	2.65	2.70	2.75	2.80	2.85	2.90	2.95	3.00	3.05	3.10	3.15	3.20	3.25	3.30	3.35	3.40	3.45	3.50	3.50	3.50	3.50
0.21-0.25	2.45	2.50	2.55	2.60	2.65	2.70	2.75	2.80	2.85	2.90	2.95	3.00	3.05	3.10	3.15	3.20	3.25	3.30	3.35	3.40	3.45	3.50	3.50	3.50	3.50	3.50
0.26-0.30	2.50	2.55	2.60	2.65	2.70	2.75	2.80	2.85	2.90	2.95	3.00	3.05	3.10	3.15	3.20	3.25	3.30	3.35	3.40	3.45	3.50	3.50	3.50	3.50	3.50	3.50
0.31-0.35	2.55	2.60	2.65	2.70	2.75	2.80	2.85	2.90	2.95	3.00	3.05	3.10	3.15	3.20	3.25	3.30	3.35	3.40	3.45	3.50	3.50	3.50	3.50	3.50	3.50	3.50
0.36-0.40	2.55	2.60	2.65	2.70	2.75	2.80	2.85	2.90	2.95	3.00	3.05	3.10	3.15	3.20	3.25	3.30	3.35	3.40	3.45	3.50	3.50	3.50	3.50	3.50	3.50	3.50
0.41-0.45	2.60	2.65	2.70	2.75	2.80	2.85	2.90	2.95	3.00	3.05	3.10	3.15	3.20	3.25	3.30	3.35	3.40	3.45	3.50	3.50	3.50	3.50	3.50	3.50	3.50	3.50
0.46-0.50	2.65	2.70	2.75	2.80	2.85	2.90	2.95	3.00	3.05	3.10	3.15	3.20	3.25	3.30	3.35	3.40	3.45	3.50	3.50	3.50	3.50	3.50	3.50	3.50	3.50	3.50
0.51-0.55	2.70	2.75	2.80	2.85	2.90	2.95	3.00	3.05	3.10	3.15	3.20	3.25	3.30	3.35	3.40	3.45	3.50	3.50	3.50	3.50	3.50	3.50	3.50	3.50	3.50	3.50
0.56-0.60	2.75	2.80	2.85	2.90	2.95	3.00	3.05	3.10	3.15	3.20	3.25	3.30	3.35	3.40	3.45	3.50	3.50	3.50	3.50	3.50	3.50	3.50	3.50	3.50	3.50	3.50
0.61-0.65	2.80	2.85	2.90	2.95	3.00	3.05	3.10	3.15	3.20	3.25	3.30	3.35	3.40	3.45	3.50	3.50	3.50	3.50	3.50	3.50	3.50	3.50	3.50	3.50	3.50	3.50
0.66-0.70	2.85	2.90	2.95	3.00	3.05	3.10	3.15	3.20	3.25	3.30	3.35	3.40	3.45	3.50	3.50	3.50	3.50	3.50	3.50	3.50	3.50	3.50	3.50	3.50	3.50	3.50
0.71-0.75	2.90	2.95	3.00	3.05	3.10	3.15	3.20	3.25	3.30	3.35	3.40	3.45	3.50	3.50	3.50	3.50	3.50	3.50	3.50	3.50	3.50	3.50	3.50	3.50	3.50	3.50
0.76-0.80	2.95	3.00	3.05	3.10	3.15	3.20	3.25	3.30	3.35	3.40	3.45	3.50	3.50	3.50	3.50	3.50	3.50	3.50	3.50	3.50	3.50	3.50	3.50	3.50	3.50	3.50
0.81-0.85	3.00	3.05	3.10	3.15	3.20	3.25	3.30	3.35	3.40	3.45	3.50	3.50	3.50	3.50	3.50	3.50	3.50	3.50	3.50	3.50	3.50	3.50	3.50	3.50	3.50	3.50
0.86-0.90	3.05	3.10	3.15	3.20	3.25	3.30	3.35	3.40	3.45	3.50	3.50	3.50	3.50	3.50	3.50	3.50	3.50	3.50	3.50	3.50	3.50	3.50	3.50	3.50	3.50	3.50
0.91-0.95	3.10	3.15	3.20	3.25	3.30	3.35	3.40	3.45	3.50	3.50	3.50	3.50	3.50	3.50	3.50	3.50	3.50	3.50	3.50	3.50	3.50	3.50	3.50	3.50	3.50	3.50
0.96-1.00	3.15	3.20	3.25	3.30	3.35	3.40	3.45	3.50	3.50	3.50	3.50	3.50	3.50	3.50	3.50	3.50	3.50	3.50	3.50	3.50	3.50	3.50	3.50	3.50	3.50	3.50
1.01-1.05	3.20	3.25	3.30	3.35	3.40	3.45	3.50	3.50	3.50	3.50	3.50	3.50	3.50	3.50	3.50	3.50	3.50	3.50	3.50	3.50	3.50	3.50	3.50	3.50	3.50	3.50
1.06-1.10	3.25	3.30	3.35	3.40	3.45	3.50	3.50	3.50	3.50	3.50	3.50	3.50	3.50	3.50	3.50	3.50	3.50	3.50	3.50	3.50	3.50	3.50	3.50	3.50	3.50	3.50
1.11-1.15	3.30	3.35	3.40	3.45	3.50	3.50	3.50	3.50	3.50	3.50	3.50	3.50	3.50	3.50	3.50	3.50	3.50	3.50	3.50	3.50	3.50	3.50	3.50	3.50	3.50	3.50
1.16-1.20	3.35	3.40	3.45	3.50	3.50	3.50	3.50	3.50	3.50	3.50	3.50	3.50	3.50	3.50	3.50	3.50	3.50	3.50	3.50	3.50	3.50	3.50	3.50	3.50	3.50	3.50
1.21-1.25	3.40	3.45	3.50	3.50	3.50	3.50	3.50	3.50	3.50	3.50	3.50	3.50	3.50	3.50	3.50	3.50	3.50	3.50	3.50	3.50	3.50	3.50	3.50	3.50	3.50	3.50
1.26-1.30	3.45	3.50	3.50	3.50	3.50	3.50	3.50	3.50	3.50	3.50	3.50	3.50	3.50	3.50	3.50	3.50	3.50	3.50	3.50	3.50	3.50	3.50	3.50	3.50	3.50	3.50
1.31-1.35	3.50	3.50	3.50	3.50	3.50	3.50	3.50	3.50	3.50	3.50	3.50	3.50	3.50	3.50	3.50	3.50	3.50	3.50	3.50	3.50	3.50	3.50	3.50	3.50	3.50	3.50
1.36-1.40	3.50	3.50	3.50	3.50	3.50	3.50	3.50	3.50	3.50	3.50	3.50	3.50	3.50	3.50	3.50	3.50	3.50	3.50	3.50	3.50	3.50	3.50	3.50	3.50	3.50	3.50

**How to use this chart:**

- I. Measure tappet clearance when the engine is cold.
- II. Measure present shim size.
- III. Match clearance in vertical column with present shim size in horizontal column.

**Example:**

Tappet clearance is           0.23 mm  
 Present shim size           2.70 mm  
 Shim size to be used       2.80 mm



---

---

## Testing Engine Compression

---

To test engine compression, use the following procedure.

1. Remove the high tension lead from the spark plug.
2. Using compressed air, blow any debris from around the spark plug.

### **WARNING**

**Always wear safety glasses when using compressed air.**

3. Remove the spark plug; then attach the high tension lead to the plug and ground the plug on the cylinder head well away from the spark plug hole.
4. Attach the Compression Gauge (p/n 0444-096).

■ **NOTE: The engine must be warm and the battery must be fully charged for this test.**

5. While holding the throttle lever in the full-open position, crank the engine over with the electric starter until the gauge shows a peak reading (five to 10 compression strokes). The compression should be 10.0 kg/cm<sup>2</sup> (142 psi).
6. If compression is abnormally low, inspect the following items.
  - A. Verify starter cranks engine over at normal cranking speed.
  - B. Gauge is functioning properly.
  - C. Throttle lever in the full-open position.
  - D. Valve/tappet clearance correct.
  - E. Valve bent or burned.
  - F. Valve seat burned.

■ **NOTE: To service valves, see Section 3.**

7. Pour 29.5 ml (1 fl oz) of oil into the spark plug hole, reattach the gauge, and retest compression.
8. If compression is now evident, service the piston rings (see Section 3).

---

---

## Spark Plug

---

A light brown insulator indicates that the plug is correct. A white or dark insulator indicates that the engine may need to be serviced or the carburetor may need to be adjusted. To maintain a hot, strong spark, keep the plug free of carbon.

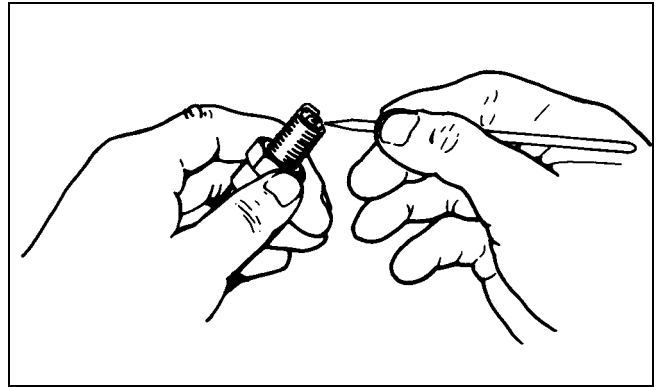

ATV-0051

### **CAUTION**

**Before removing the spark plug, be sure to clean the area around the spark plug. Dirt could enter engine when removing or installing the spark plug.**

Adjust the gap to 0.7 - 0.8 mm (0.028 - 0.032 in.). Use a feeler gauge to check the gap.

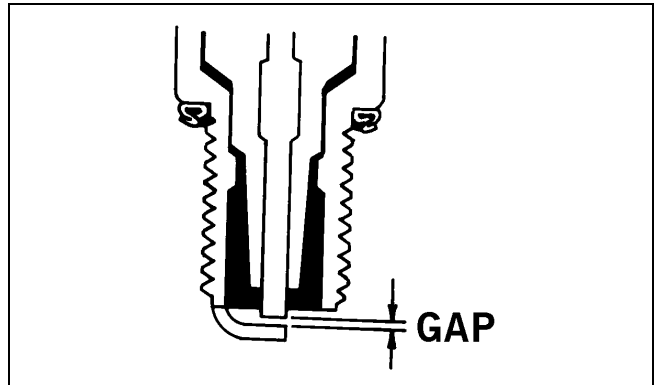

ATV0052B

When installing the spark plug, tighten to specifications.

---

---

## Muffler/Spark Arrester

---

The muffler has a spark arrester which must be periodically cleaned. At the intervals shown in the Periodic Maintenance Chart, clean the spark arrester using the following procedure.

**⚠ WARNING**

**Wait until the muffler cools to avoid burns.**

1. Remove the three Allen-head cap screws securing the spark arrester to the muffler; then remove the spark arrester.



SP001

2. Use a wire brush to remove carbon deposits from the arrester taking care not to damage the screen.



SP041

3. Check the arrester screen for holes or tears and replace components as necessary.
4. Install the spark arrester and three cap screws and tighten securely.

---

---

## Gas/Vent Hoses

---

Replace the gas hose every two years. Damage from aging may not always be visible. Do not bend or obstruct the routing of the carburetor vent hose. Make certain that the vent hose is securely connected to the carburetor and the opposite end is always open.

---

---

## Adjusting Throttle Cable

---

To adjust the throttle cable free-play, follow this procedure.

1. Slide the rubber boot away; then loosen the jam nut from the throttle cable adjuster.



AL611D

2. Slide the rubber boot away and turn the adjuster until the throttle cable has proper free-play of 3-6 mm (1/8 - 1/4 in.) at the lever.

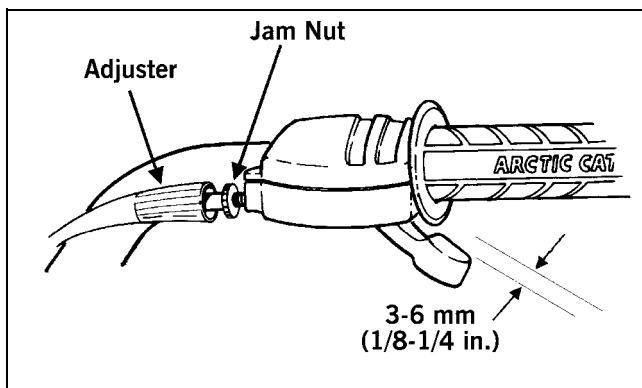

ATV-0047

3. Tighten the jam nut against the throttle cable adjuster securely; then slide the rubber boot over the adjuster.



---

---

## Adjusting Engine RPM (Idle)

---

To properly adjust the idle RPM, a tachometer is necessary. To adjust idle RPM, use the following procedure.

1. With the transmission in neutral, start the engine and warm it up to normal operating temperature.
2. Turn the idle adjustment screw (on the left side of the carburetor) clockwise one turn past the recommended RPM setting; then turn it counterclockwise to 1250-1350 RPM.

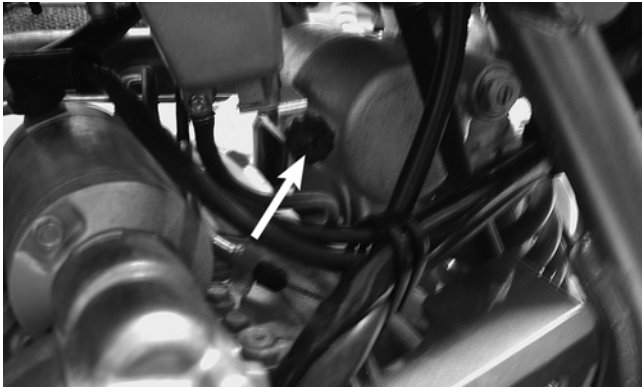

### **WARNING**

Adjust the idle to the correct RPM. Make sure the engine is at normal operating temperature before adjusting the idle RPM.

---

---

## Engine/Transmission Oil - Filter

---

### **OIL - FILTER**

Change the engine oil and oil filter at the scheduled intervals. The engine should always be warm when the oil is changed so the oil will drain easily and completely.

1. Park the ATV on level ground.

2. Loosen the oil level stick enough to allow air to vent the tank.



3. Place drain pans under the oil tank drain plug (1) and the crankcase drain plug (2); then remove the plugs and drain the oil.

# 2

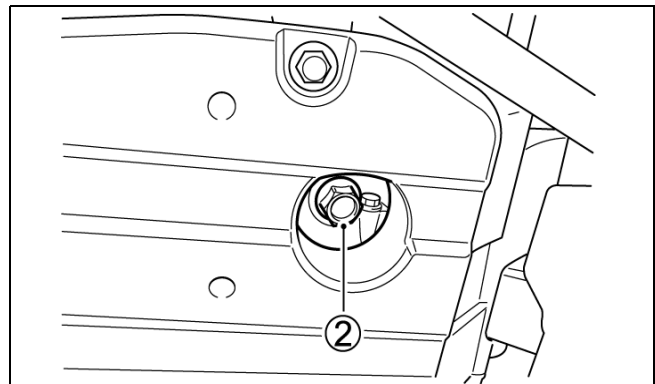
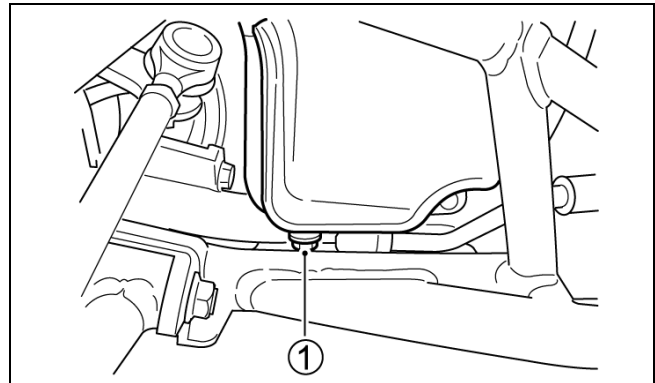

4. Remove the cap screws securing the filter cover.
5. Remove the filter cover (3); then pull out the oil filter element (4) and properly discard. Remove and properly discard the O-ring from the filter cover.

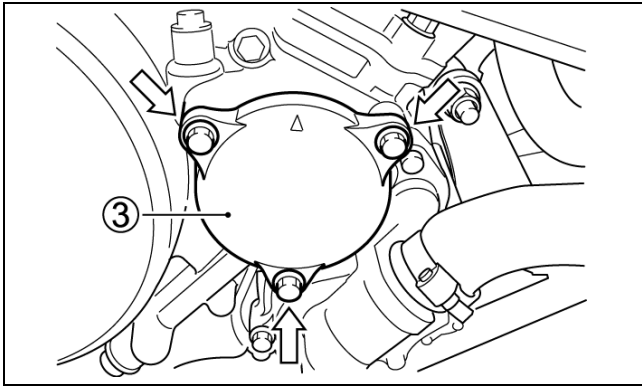

ATV2029

■ **NOTE:** Clean up any excess oil after removing the filter.

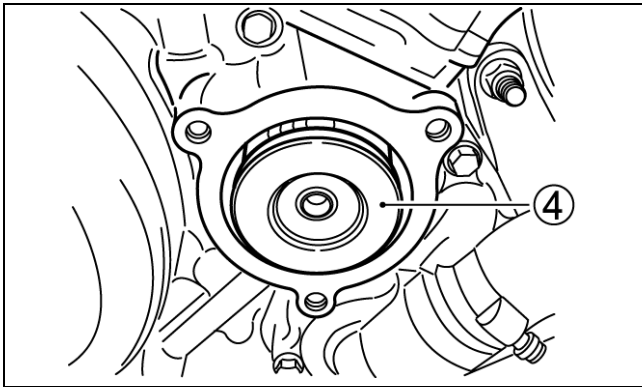

ATV2030

6. Apply oil to a new cover O-ring and check to make sure it is positioned correctly in the cover. With the open end of the filter element directed toward the center of the engine, slide the element into position.

**KEY**

- 1. Oil Pump Assy
- 2. Driven Gear
- 3. Pin
- 4. Washer
- 5. Circlip
- 6. Cap Screw
- 7. Rotor Set
- 8. Strainer
- 9. Cap Screw
- 10. Oil Filter
- 11. O-Ring
- 12. Oil Filter Cover
- 13. O-Ring
- 14. Spring
- 15. Cap Screw
- 16. Spring
- 17. Ball
- 18. Oil Check-Valve Seat
- 19. Gear
- 20. Shaft
- 21. Circlip

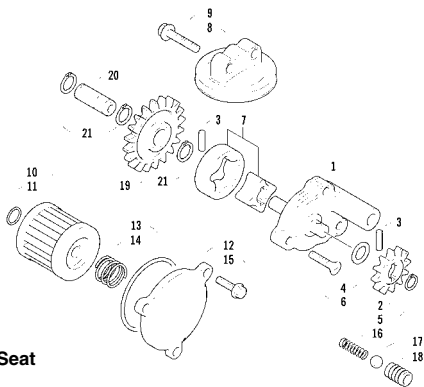

0739-215

**CAUTION**

If the oil filter element is inserted backwards, engine damage will occur due to lack of oil flow.

7. Place the filter cover in position with the triangle mark up and secure with the cap screws. Tighten securely.
8. Install the crankcase drain plug and tighten to specifications; then install the oil tank drain plug and tighten to specifications.

**CAUTION**

Any oil used in place of the recommended oil could cause serious engine damage. Do not use oils which contain graphite or molybdenum additives. These oils can adversely affect clutch operation. Also, not recommended are racing, vegetable, non-detergent, and castor-based oils.

9. Pour the recommended type and quantity of oil into the oil level stick hole; then start the engine (while the ATV is outside on level ground) and allow it to idle for a few minutes.
10. Turn the engine off and wait approximately one minute. Recheck the oil level with the oil level stick. The oil level should be between the upper and lower crosshatch marks on the level stick. Adjust oil level as necessary.

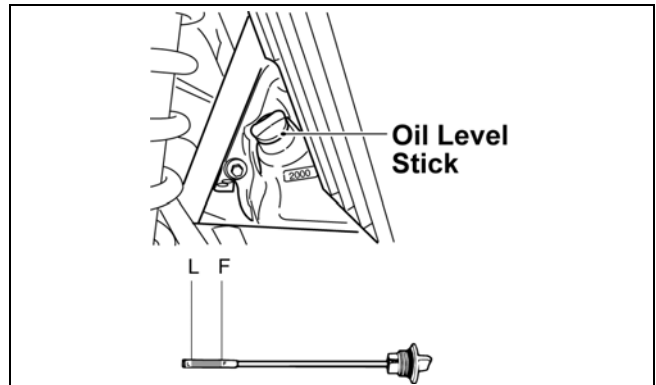

ATV2020A

11. Inspect the area around the drain plugs and oil filter for leaks.

## Adjusting Clutch Lever Cable

To adjust the cable, use the following procedure.

1. Pull rubber protective boot away from the cable adjusters.
2. Loosen the lock nut; then turn the adjuster to obtain 10-15 mm (0.4-0.6 in.) free-play measured at point (A).

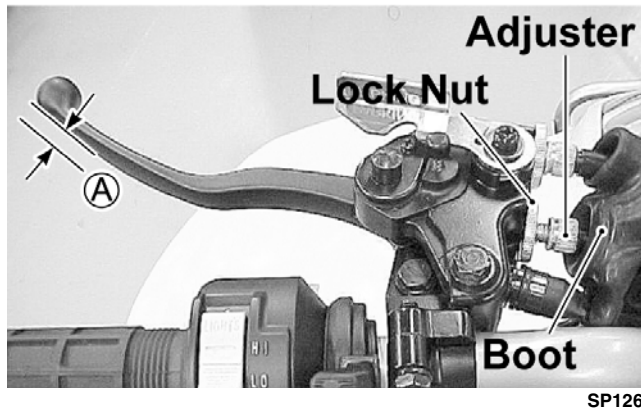

## Suspension/Shock Absorbers/Bushings

The following suspension system components should be inspected periodically to ensure proper operation.

- A. Shock absorber rods bent, pitted, or damaged.
- B. Rubber damper cracked, broken, or missing.
- C. Shock absorber body damaged, punctured, or leaking.
- D. Shock absorber eyelets broken, bent, or cracked.
- E. Shock absorber eyelet bushings worn, deteriorated, cracked, or missing.
- F. Shock absorber spring broken or sagging.

## Tires

### TIRE SIZES

The ATV is equipped with low-pressure tubeless tires of the size and type listed. Do not under any circumstances substitute tires of a different type or size.

#### **⚠ WARNING**

**Always use the size and type of tires specified. Always maintain proper tire inflation pressure.**

### TIRE INFLATION PRESSURE

Front and rear tire inflation pressure should be at recommended specifications.

A low-pressure gauge is provided in the tool kit to measure the air pressure in the tires. Check the air pressure in all tires before each use of the ATV.

## Steering Components

The following steering components should be inspected periodically to ensure safe and proper operation.

- A. Handlebar grips not worn, broken, or loose.
- B. Handlebar not bent, cracked, and has equal and complete full-left and full-right capability.
- C. Steering post bearing assembly/bearing housing not broken, worn, or binding.
- D. Ball joints not worn, cracked, or damaged.
- E. Tie rods not bent or cracked.
- F. Knuckles not worn, cracked, or damaged.
- G. Cotter pins not damaged or missing.

## Nuts/Bolts/Cap Screws

Tighten all nuts, bolts, and cap screws. Make sure rivets holding components together are tight. Replace all loose rivets. Care must be taken that all calibrated nuts, bolts, and cap screws are tightened to specifications. For proper torque values, see Section 10.

## Headlight/Taillight-Brakelight

Each time the ATV is used, lights should be checked for proper function. Rotate the ignition switch to the lights position; the headlights and taillight should illuminate. Test the brakelight by compressing the brake lever. The brakelight should illuminate.

### HEADLIGHT

**NOTE:** The bulb portion of the headlight is fragile. **HANDLE WITH CARE.** When replacing the headlight bulb, do not touch the glass portion of the bulb. If the glass is touched, it must be cleaned with a dry cloth before installing. Skin oil residue on the bulb will shorten the life of the bulb.

#### **⚠ WARNING**

**Do not attempt to remove the bulb when it is hot. Severe burns may result.**

To replace the headlight bulb, use the following procedure.

1. Turn the bulb counterclockwise; then remove from the reflector housing.
2. Disconnect the two-wire connector from the bulb; then connect the new bulb to the connector.
3. Install the bulb into the reflector housing and turn the bulb clockwise to lock.

### TAILLIGHT-BRAKELIGHT

To replace the taillight-brakelight bulb, use the following procedure.

1. Twist the socket counterclockwise to remove it from the the taillight housing.



SP089

2. Pull the bulb straight out of the socket; then install the new bulb.



SP085

3. Install the socket in the taillight housing by pushing in and turning clockwise.

#### CAUTION

Tighten the lens cover screws only until they are snug.

### CHECKING/ADJUSTING HEADLIGHT AIM

The headlights can be adjusted vertically and horizontally. The geometric center of the HIGH beam light zone is to be used for vertical and horizontal aiming.

1. Position the ATV on a level floor so the headlights are approximately 6.1 m (20 ft) from an aiming surface (wall or similar aiming surface).

■ **NOTE:** There should be an average operating load on the ATV when adjusting the headlight aim.

2. Measure the distance from the floor to the mid-point of each headlight.
3. Using the measurements obtained in step 2, make horizontal marks on the aiming surface.
4. Make vertical marks which intersect the horizontal marks on the aiming surface directly in front of the headlights.
5. Switch on the lights. Make sure the HIGH beam is on. DO NOT USE LOW BEAM.
6. Observe each headlight beam aim. Proper aim is when the most intense beam is centered on the vertical mark 5 cm (2 in.) below the horizontal mark on the aiming surface.

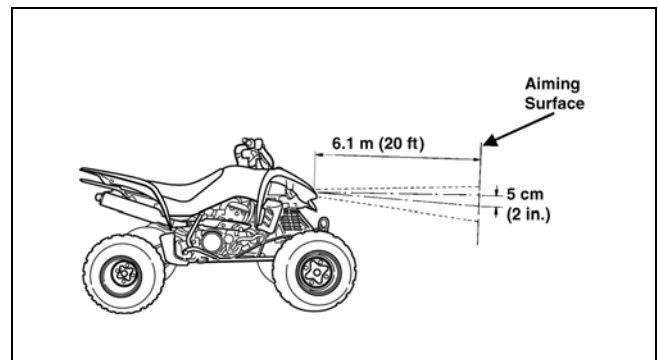

ATV2051B

7. Adjust each headlight until correct aim is obtained.
  - A. Horizontal — Loosen nut (A) and adjust for proper aiming. Tighten the nut securely.
  - B. Vertical— Loosen nut (B) and adjust for proper aiming. Tighten the nut securely.

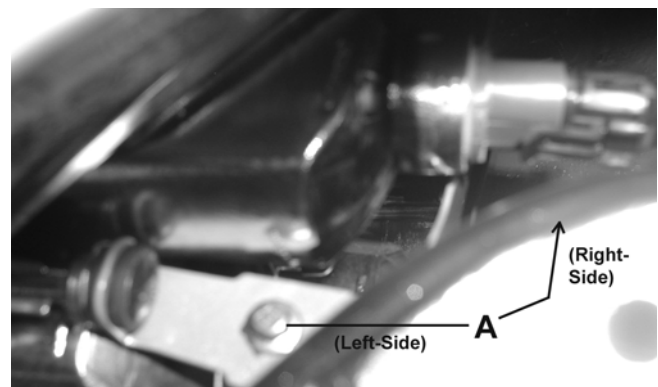

SP095A



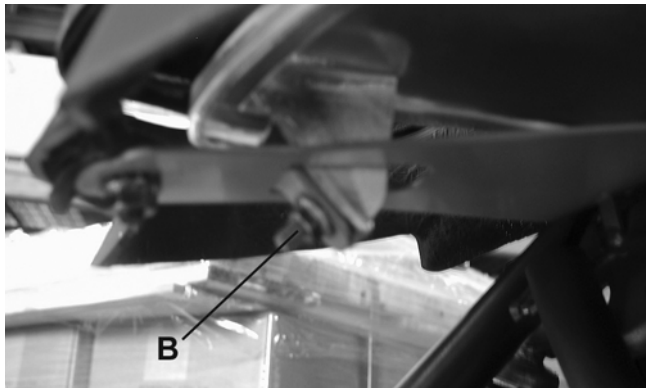

SP094A

## Switches

Each time the ATV is used, switches should be checked for proper operation. Use the following list for reference.

- A. Ignition switch — engine will start.
- B. Emergency stop switch — engine will stop.
- C. Reverse switch — reverse indicator light illuminates.
- D. Hi/Lo switch — headlight beam bright and dim.
- E. Brake switches — rear brakelight illuminates.
- F. Neutral switch — neutral indicator light illuminates when transmission is in neutral.

## Indicator Lights

Each time the ATV is used, the lights should be checked for proper function. Use the following for reference.

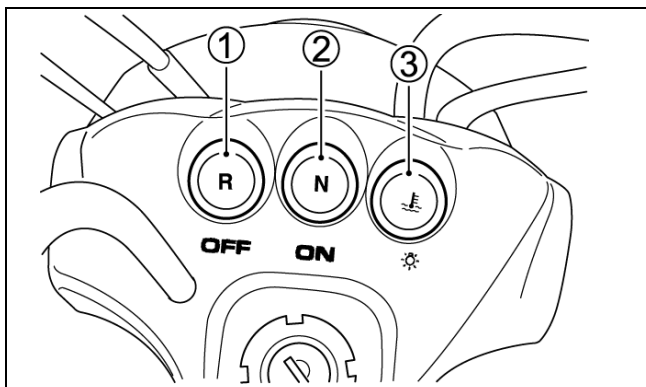

ATV2007

1. **Reverse Indicator** — A red light will illuminate when the transmission is shifted into reverse gear. The light will go off when shifted out of reverse.

2. **Neutral Indicator** — A green light will illuminate when the transmission is in neutral and the ignition switch is on. The light will go out when shifted into any gear other than neutral.
3. **Temperature Indicator** — A red light will illuminate if the engine overheats. The light should be off during normal operation.

### CAUTION

Continued operation of the ATV with high engine temperature may result in engine damage or premature wear.

■ **NOTE:** High engine RPM, low vehicle speed, or heavy load can raise engine temperature. Decreasing engine RPM, reducing load, and selecting an appropriate transmission gear can lower the temperature.

■ **NOTE:** Debris between the cooling fins of the radiator can reduce cooling capability. Using a hose, pressure-wash the radiator to remove any debris preventing air flow.

2

## Frame/Welds

The frame and welds should be checked periodically for damage, bends, cracks, deterioration, broken components, and missing components. If replacement or repair constitutes removal, see Section 8.

## Electrical Connections

The electrical connections should be checked periodically for proper function. In case of an electrical failure, check fuse, connections (for tightness, corrosion, damage), and/or bulbs. If an electrical component needs to be tested for proper function, see Section 5.

## Hydraulic/Parking Brake Systems

### CHECKING/BLEEDING

The hydraulic brake systems have been filled and bled at the factory. To check and/or bleed a hydraulic brake system, use the following procedure.

1. With the front brake master cylinder in a level position, check the fluid level in the reservoir. If the level in the reservoir is not visible in the sight glass, add DOT 4 brake fluid.

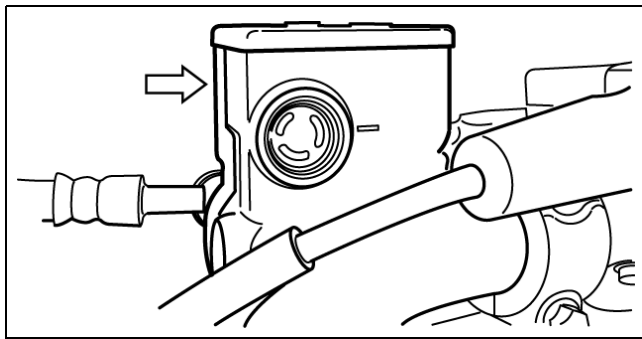

ATV2037

2. Compress the brake lever several times to check for a firm brake. If the brake is not firm, the front brake system must be bled.
3. Remove the rear brake reservoir cap. If the level in the reservoir is not above the mark, add DOT 4 brake fluid.

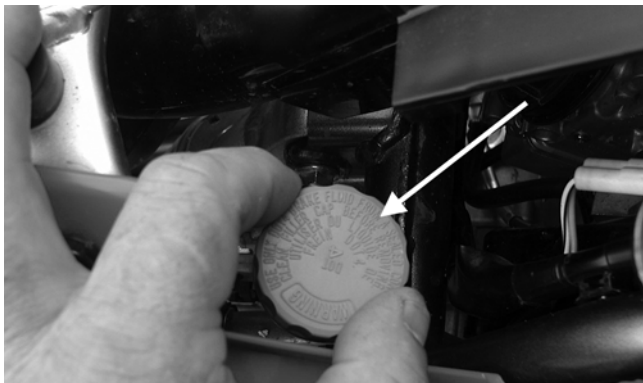

SP111A

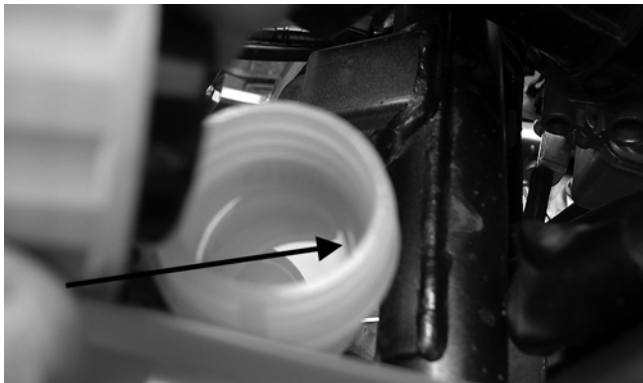

SP112A

4. Depress the brake pedal several times to check for a firm pedal. If the pedal is not firm, the rear brake system must be bled.

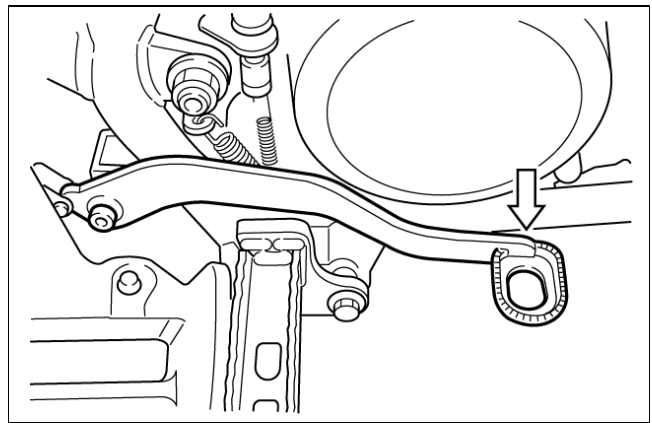

ATV2009

5. To bleed the front brake system, use the following procedure.

- A. Remove the cover and fill the reservoir with DOT 4 Hi-Temp Brake Fluid (p/n 1639-799).



SP028

- B. Install and secure the cover; then slowly compress the brake lever several times.

- C. Remove the protective cap, install one end of a clear hose onto one FRONT bleeder screw, and direct the other end into a container; then while holding slight pressure on the brake lever, open the bleeder screw and watch for air bubbles. Close the bleeder screw before releasing the brake lever. Repeat this procedure until no air bubbles are present.



AF637D

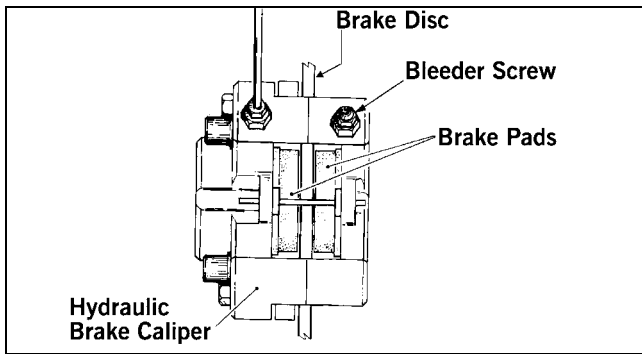

730-434B

■ **NOTE:** During the bleeding procedure, watch the reservoir sight glass very closely to make sure there is always a sufficient amount of brake fluid. Failure to maintain a sufficient amount of fluid in the reservoir will result in air in the system.

- D. Repeat step C until no air bubbles are observed in the bleeder line. Close the bleeder screw and tighten.
- E. Perform steps B,C, and D on the other FRONT bleeder screw repeating step C until no air bubbles are observed in the bleeder line. Make sure that the brake lever is firm.

■ **NOTE:** If the brake lever is still not firm, it may be necessary to do the entire front brake bleeding procedure over.

- 6. To bleed the rear brake system, use the following procedure.
  - A. Remove the rear brake reservoir cap and fill the reservoir with DOT 4 Hi-Temp Brake Fluid (p/n 1639-799).
  - B. Install and tighten the cover; then depress the brake pedal several times.
  - C. Remove the protective cap, install one end of a clear hose on the REAR bleeder screw, and direct the other end into a container; then while holding slight pressure on the brake pedal, open the bleeder screw and watch for air bubbles. Close the bleeder screw before releasing the brake pedal. Repeat this procedure until no air bubbles are present.
  - D. Repeat step C until the brake pedal is firm.
- 7. Carefully inspect the hydraulic brake hoses for cracks or other damage. If found, the brake hoses must be replaced.

**CAUTION**

This hydraulic brake system is designed to use high-temperature DOT 4 brake fluid only. If brake fluid must be added, care must be taken as brake fluid is very corrosive to painted surfaces.

**INSPECTING HOSES**

Carefully inspect the hydraulic brake hoses for cracks or other damage. If found, the brake hoses must be replaced.

**MEASURING/REPLACING FRONT BRAKE PADS**

The clearance between the brake pads and brake discs is adjusted automatically as the brake pads wear. The only maintenance that is required is replacement of the brake pads when they show excessive wear. Check the thickness of each of the brake pads as follows.

1. Remove the front wheels.
2. Measure the thickness of each brake pad.

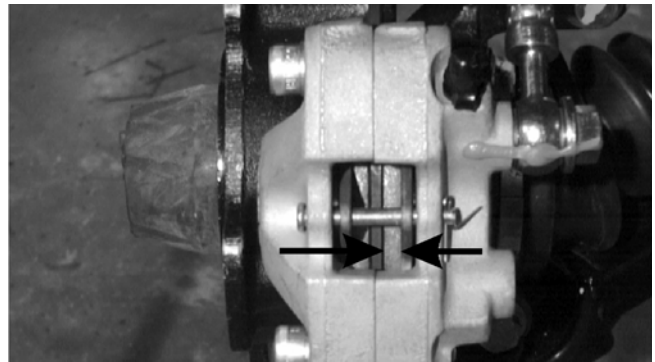

AF739DB

**2**

3. If thickness of any brake pad is less than 2.0 mm (0.078 in.), all brake pads must be replaced.

■ **NOTE:** The brake pads should be replaced as a complete set.

4. To replace the brake pads, use the following procedure.
  - A. Remove the caliper mounting cap screws (1) and the brake pad mounting pins (2); then remove the brake pads. Account for the shims.

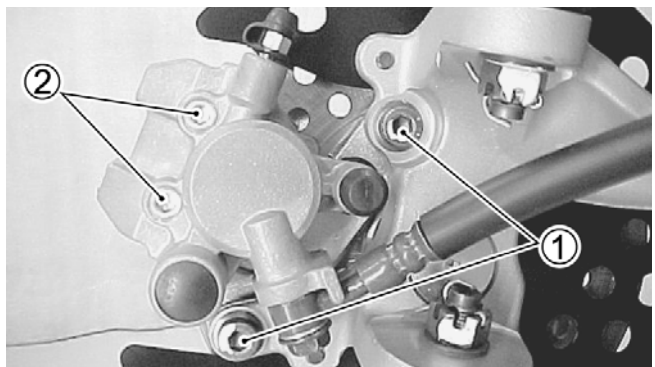

SP127

■ **NOTE:** Do not compress the brake lever after the brake pads are removed.

■ **NOTE:** Inspect the brake pad mounting pins (2) for wear. If excessive wear is found, the pins must be replaced.



■ **NOTE:** The shim must be installed on the piston side brake pad.

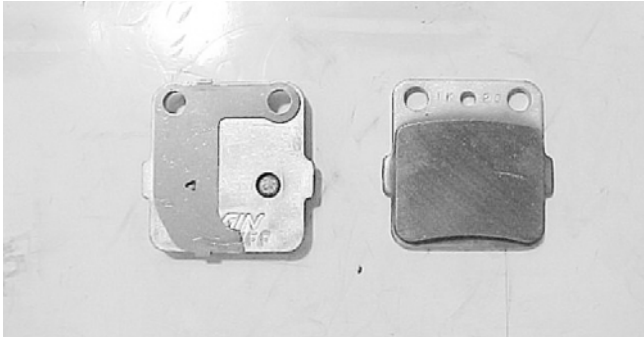

SP128

■ **NOTE:** Make sure the detent of the brake pad is fitted to the recess on the brake caliper bracket.

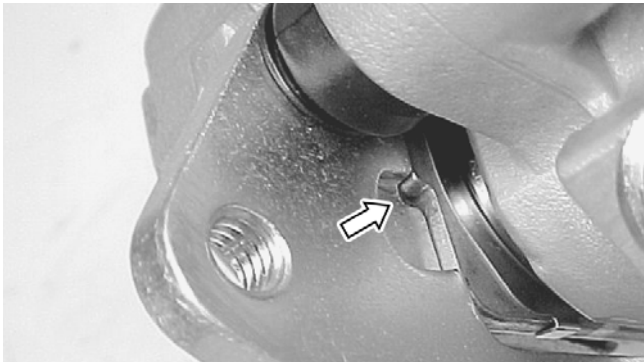

SP129

B. Install the new brake pads; then tighten the brake pad mounting pins and the brake caliper mounting cap screws to specifications.

■ **NOTE:** After replacing the brake pads, compress the brake lever several times to check for proper brake operation; then check the brake fluid level.

C. Install the wheels and tighten to specifications using a crisscross pattern.



SP018A

5. Burnish the brake pads (see Burnishing Brake Pads in this section).

## MEASURING/REPLACING REAR BRAKE PADS

1. Release the parking brake, if applied; then remove two cap screws securing the brake caliper assembly to the rear housing.

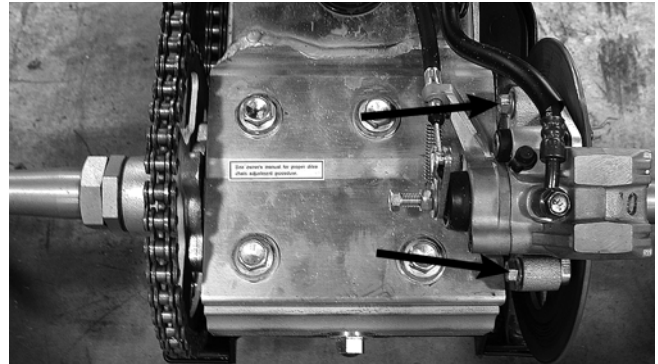

SP061C

■ **NOTE:** Do not depress the brake pedal as this will push the piston out spilling brake fluid. The rear brake system will have to be refilled and bled if this occurs.

2. Bend down the tabs on the washer and remove the brake pad mounting pins; then remove the brake pads.

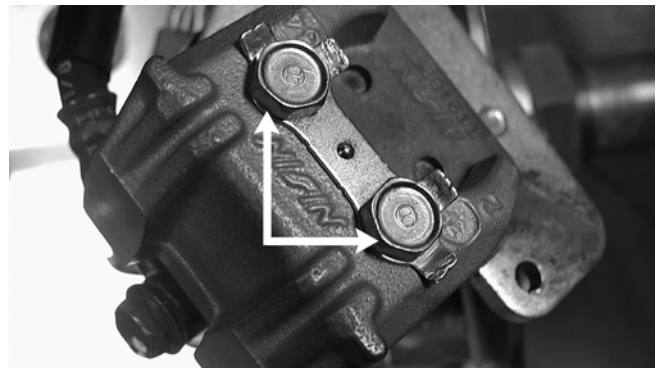

SP114A

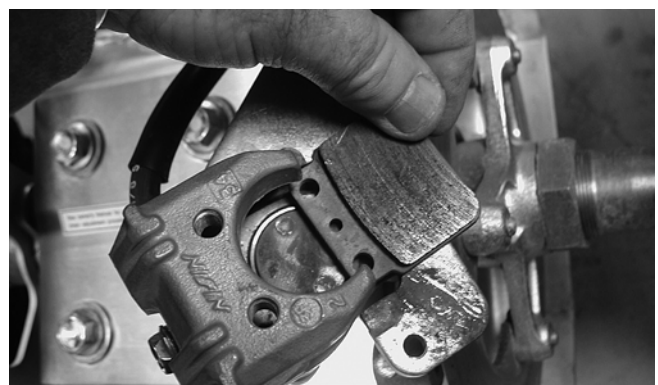

SP116

3. Inspect the pads for gouges, chips, or wear.
4. Inspect the disc for gouges, grooves, cracks, and warpage.
5. Using a calipers, measure the thickness of each brake pad.



- If the thickness of any brake pad is less than 2.0 mm (0.078 in.), all brake pads must be replaced.

■ **NOTE:** The brake pads should be replaced as a complete set.

- Using compressed air, blow dust and brake pad residue from the caliper; then install new brake pads and secure with the two mounting pins. Tighten to specifications and lock with the tabs on the washer.

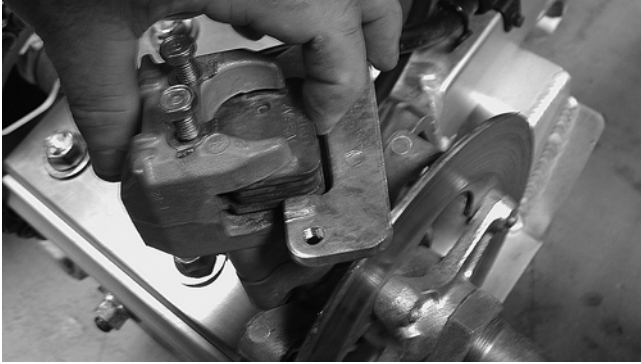

SP117

- Carefully separate the brake pads to allow the assembly to slip over the rotor; then install and secure to the rear housing with the two cap screws. Tighten to specifications.

■ **NOTE:** It may be necessary to loosen the parking brake adjuster screws in order to open the pads sufficiently to clear the rotor. Anytime the rear brake pads are replaced, the parking brake **MUST** be adjusted.

### ADJUSTING PARKING BRAKE

To adjust the parking brake, use the following procedure.

- Loosen the parking brake adjuster lock nut (1) while holding the adjuster (2) with a screwdriver; then turn the adjuster counterclockwise several turns.

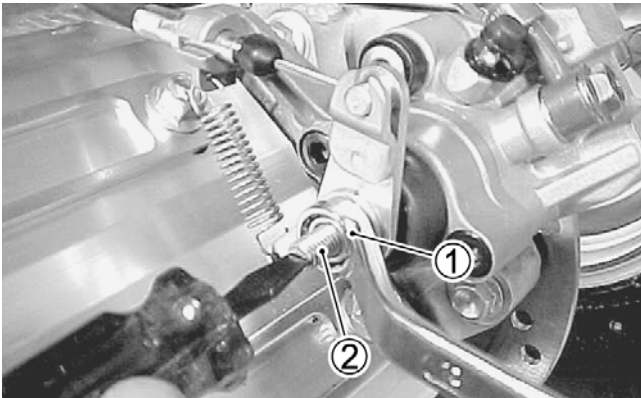

SP130

- Loosen the parking brake cable adjuster (3) and turn the adjuster (4) to achieve a cable length of 47-51 mm (1.9-2.0 in.) at (A).

- Tighten the adjuster lock nut (3).

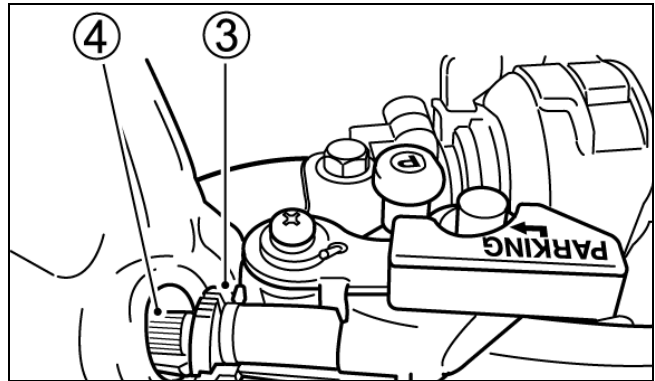

ATV2154

**2**

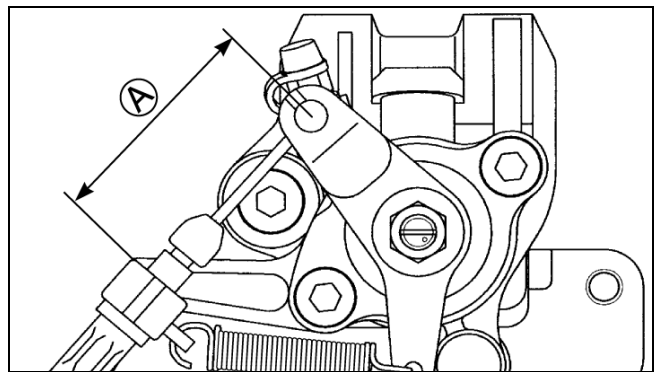

ATV2155

- Turn the brake adjuster screw (2) clockwise until it stops; then back up adjuster 1/8-1/4 turn.

- Hold the adjuster screw (2) in position and tighten the lock nut (1) to specifications.

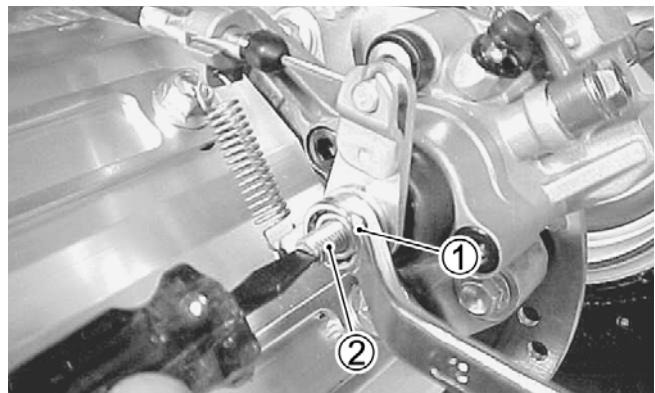

SP130

■ **NOTE:** Check that rear wheels turn freely when the parking brake is released and that they lock when the parking brake is engaged and locked.

---

---

## Burnishing Brake Pads

---

Brake pads (both hydraulic and auxiliary) must be burnished to achieve full braking effectiveness. Braking distance will be extended until brake pads are properly burnished. To properly burnish the brake pads, use the following procedure.

### **WARNING**

**Failure to properly burnish the brake pads could lead to premature brake pad wear or brake loss. Brake loss can result in severe injury.**

1. Choose an area large enough to safely accelerate the ATV to 30 mph and to brake to a stop.
2. Accelerate to 30 mph; then compress brake lever or apply the auxiliary brake to decelerate to 0-5 mph.
3. Repeat procedure on each brake system five times until brake pads are burnished.
4. Adjust the parking brake (if necessary).
5. Verify that the brakelight illuminates when the hand lever is compressed or the brake pedal is depressed.

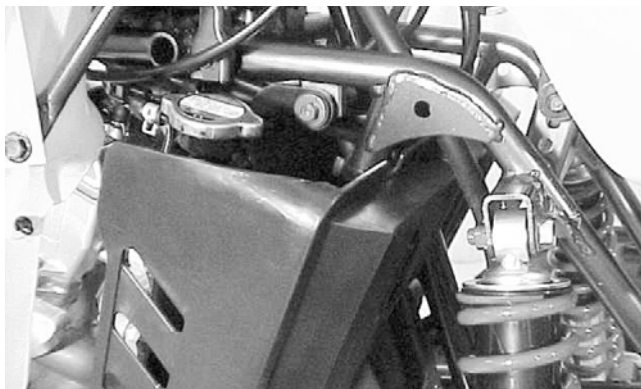

SP131



SP019

### **CAUTION**

**After operating the ATV for the initial 5-10 minutes, stop the engine, allow the engine to cool down, and check the coolant level. Add coolant as necessary.**

---

---

## Coolant

---

The cooling system capacity is approximately 1.2 L (1.3 U.S. qt). The cooling system should be inspected daily for leakage and damage. Also, the coolant level should be checked periodically.

When filling the cooling system, use premixed Arctic Cat Antifreeze (p/n 0638-395). While the cooling system is being filled, air pockets may develop; therefore, run the engine for five minutes after the initial fill, shut the engine off, and then fill the cooling system to the bottom of the stand pipe in the radiator neck (1). Make sure the coolant level in the overflow tank is between the upper and lower marks.

---

---

## Drive Chain

---

### **INSPECTING**

To properly check the drive chain for defects, support the ATV with a jack or suitable block under the swing arm allowing the rear wheels to turn freely. With the transmission in neutral, slowly rotate the wheels and inspect the drive chain for the following items:

1. Loose Pins
2. Damaged Rollers
3. Dry or Rusted Links
4. Kinked or Binding Links
5. Excessive Wear
6. Improper Adjustment
7. Missing O-Ring Seals



## MEASURING

1. Loosen the four cap screws on top of the axle housing; then turn the adjuster nut clockwise until all slack is out of the chain.

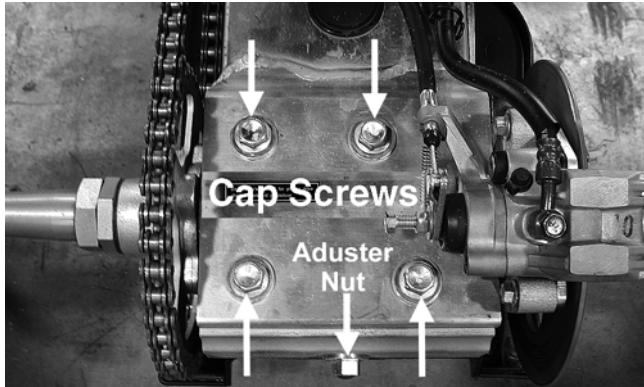

SP061A

2. Count out 21 pins on the chain and measure the distance between the two points. If this distance exceeds the service limit of 319.4 mm (12.57 in.), the chain must be replaced.

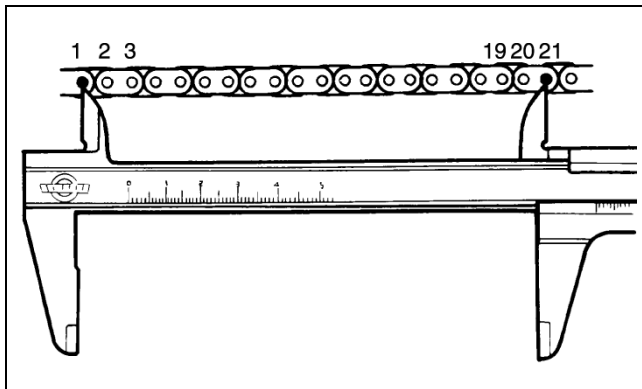

ATV2156

## ADJUSTING

To adjust the drive chain, use the following procedure.

1. Loosen the four cap screws on the top of the axle housing; then turn the adjuster nut on the rear of the axle housing until the chain has 30-40 mm (1.2-1.6 in.) slack midway between the chain buffer and the rear sprocket.

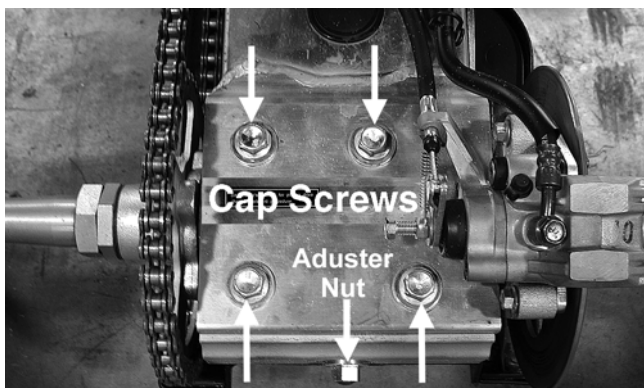

SP061A

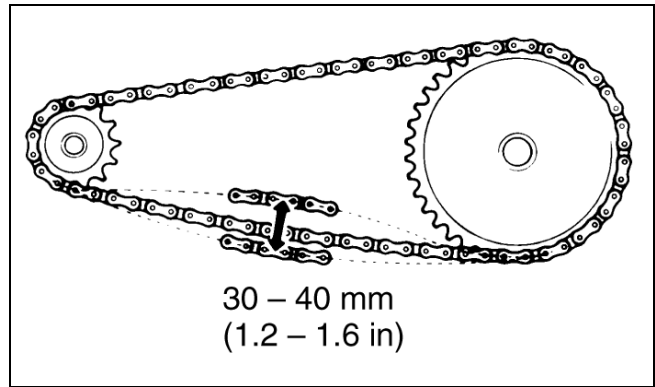

ATV2157

2. Tighten the four cap screws to specifications and recheck the chain tension.

## REPLACING

■ **NOTE:** When replacing the drive chain, replace the chain and sprockets as a set.

1. Place the ATV on a level surface and block the front wheels; then raise the rear end and place support under the axle housing.
2. Remove the left-rear wheel; then remove the cotter pin, hub nut, flat washer, and the hub.

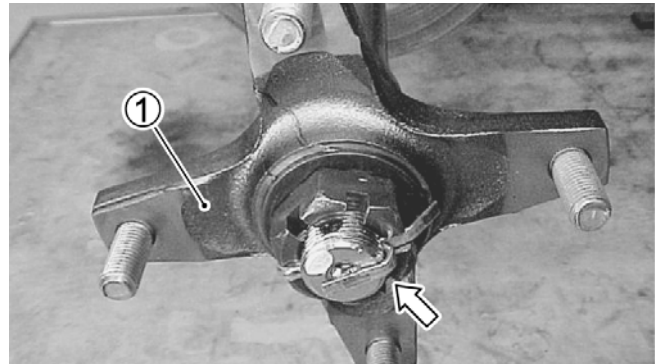

SP132

3. Loosen the four cap screws on top of the axle housing; then slacken the chain by turning the adjuster nut counterclockwise.

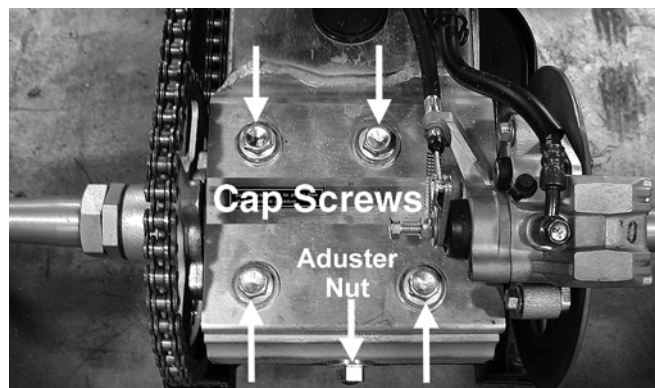

SP061A

4. Locate and remove the master link (chain connector link); then remove the drive chain.

5. Remove the four cap screws securing the driven sprocket to the sprocket hub; then remove the sprocket from the axle.
6. Remove the two cap screws securing the drive sprocket cover; then remove the cover.

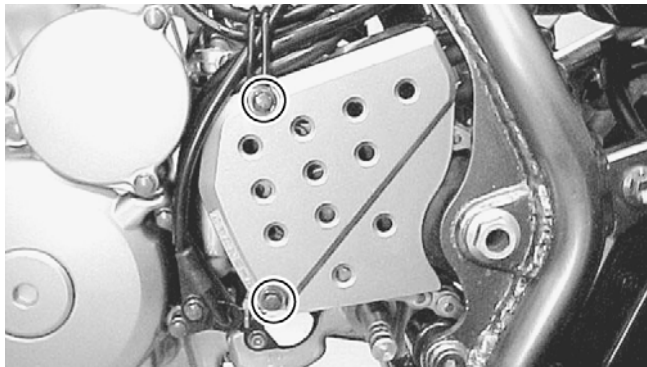

SP134

7. Remove the drive sprocket cap screws and remove the sprocket.
8. Install a new drive sprocket; then apply red Loctite #271 to the drive sprocket cap screws and tighten to specifications.
9. Install a new driven sprocket; then apply red Loctite #271 to the sprocket mounting cap screws and tighten to specifications.
10. Install a new chain and adjust as recommended in this sub-section.
11. Install the drive sprocket cover and tighten securely.

12. Lightly lubricate the axle spline with multipurpose grease; then install the hub, flat washer, and the hub nut and tighten to specifications.

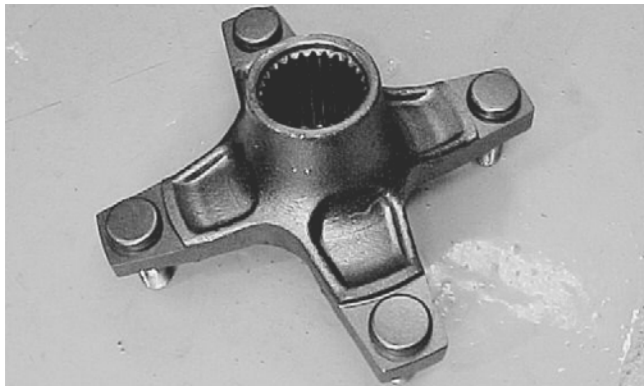

SP136

13. Install a new cotter pin; then install the wheel and tighten the lug nuts to specifications using a criss-cross pattern.



SP018A